

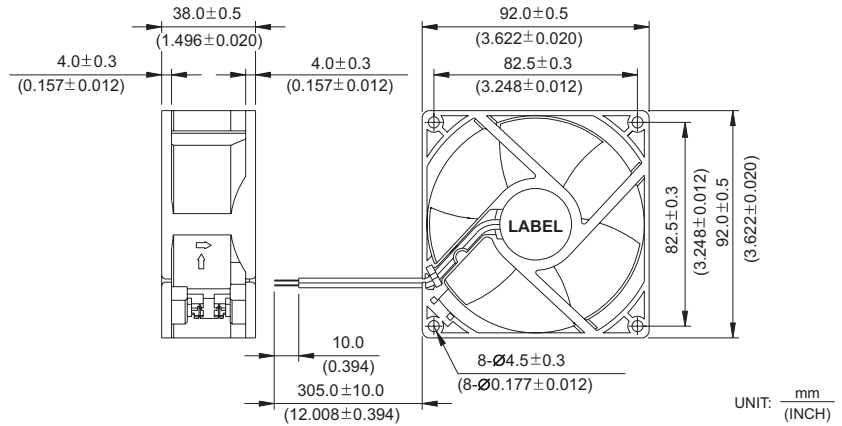

■ DIMENSIONS DRAWING



- * Bearing Type
Ball Bearings
- * Material
Impeller & Frame : Plastic (UL 94V-0)
- * Lead Wires :
UL 1007 AWG #24 OR Equivalent
Red Wire Positive (+)
Black Wire Negative (-)
- * Weight : 140g (4.94 oz)

■ P & Q CURVE (AT RATED VOLTAGE)

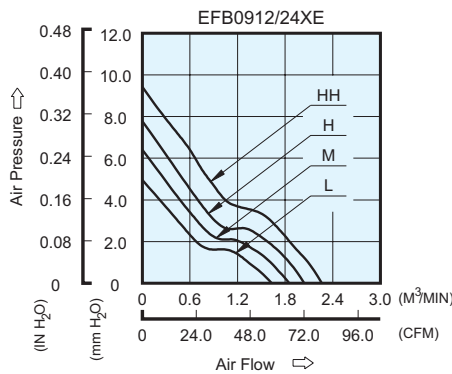

■ MOUNTING PANEL CUTOUT

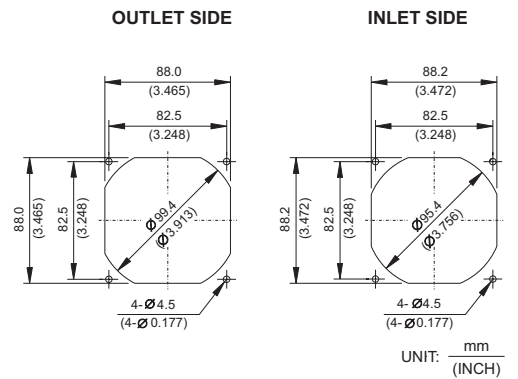

MODEL		Rated Voltage	Operating Voltage Range	Rated Current	Rated Input Power	Speed	Maximum Air Flow		Maximum Air Pressure		Noise
PART NO.	FUNCTION	VDC	VDC	Amp	Watt	R.P.M.	m ³ / min	CFM	mmH ₂ O	IN H ₂ O	dB-A
EFB0912LE	-R00 / -F00	12	7.0 to 13.8	0.17	2.04	2800	1.631	57.60	4.95	0.195	36.0
EFB0924LE	-R00 / -F00	24	14.0 to 27.6	0.09	2.16						
EFB0912ME	-R00 / -F00	12	7.0 to 13.8	0.24	2.88	3200	1.852	65.40	6.40	0.252	40.0
EFB0924ME	-R00 / -F00	24	14.0 to 27.6	0.11	2.64						
EFB0912HE	-R00 / -F00	12	7.0 to 13.8	0.32	3.84	3600	2.042	72.11	7.77	0.306	43.0
EFB0924HE	-R00 / -F00	24	14.0 to 27.6	0.16	3.84						
EFB0912HHE	-R00 / -F00	12	7.0 to 13.2	0.42	5.04	4000	2.260	79.81	9.42	0.371	46.0
EFB0924HHE	-R00 / -F00	24	14.0 to 27.6	0.20	4.80						

* Function type is optional.
 * The max. air flow and the speed are measured in free air ; max. air pressure is measured at zero air flow.
 * Noise is measured in anechoic chamber in free air, one meter from intake side.
 * All readings are typical values at rated voltage.
 * Specifications are subject to change without notice.

北京永宏诚大机电设备有限责任公司 电话:86-10-66131492
 传真:86-10-66162242