

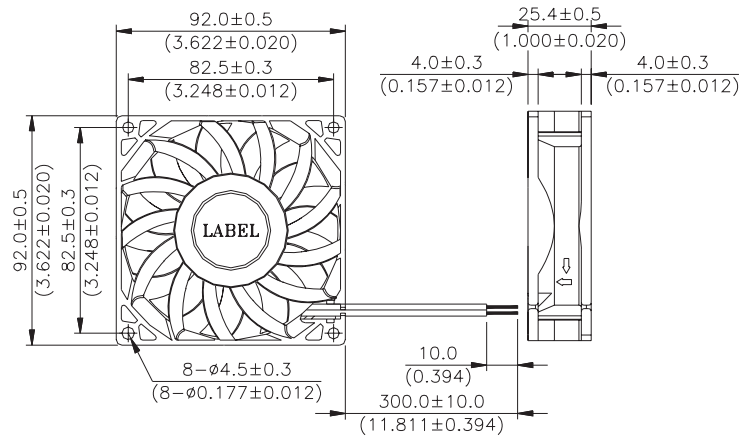

- \* Bearing Type  
Ball Bearings
- \* Material  
Impeller & Frame : Plastic(UL 94V-0)
- \* Lead Wires :  
UL 1007 AWG #24 OR Equivalent  
Red Wire Positive(+)  
Black Wire Negative(-)
- \* Weight : 128g (4.51 OZ)

■ DIMENSIONS DRAWING



■ P & Q CURVE (AT RATED VOLTAGE)

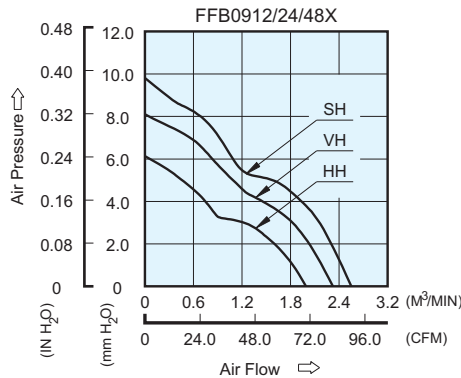

■ MOUNTING PANEL CUTOUT

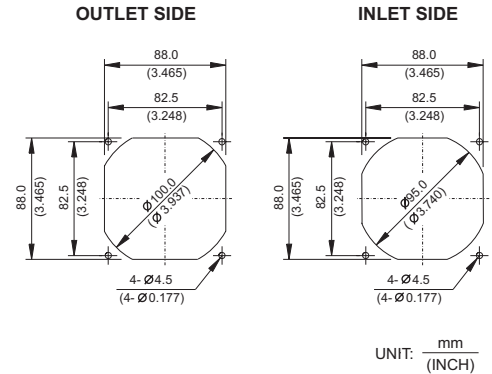

MODEL		Rated Voltage	Operating Voltage Range	Rated Current	Rated Input Power	Speed	Maximum Air Flow		Maximum Air Pressure		Noise
PART NO.	FUNCTION	VDC	VDC	Amp	Watt	R.P.M.	M <sup>3</sup> /min	CFM	mm H <sub>2</sub> O	IN H <sub>2</sub> O	dB-A
FFB0912HH	-R00 / -F00	12	7.0 to 13.8	0.40	4.80	3200	1.988	70.21	6.14	0.242	44.1
FFB0924HH	-R00 / -F00	24	14.0 to 27.6	0.24	5.76						
FFB0948HH	-R00 / -F00	48	28.0 to 53.0	0.14	6.72						
FFB0912VH	-R00 / -F00	12	7.0 to 13.8	0.60	7.20	3700	2.321	81.97	8.11	0.319	48.2
FFB0924VH	-R00 / -F00	24	14.0 to 27.6	0.31	7.44						
FFB0948VH	-R00 / -F00	48	28.0 to 53.0	0.17	8.16						
FFB0912SH	-R00 / -F00	12	7.0 to 13.8	0.69	8.28	4100	2.550	90.05	10.06	0.396	50.0

\* Function type is optional.  
 \* The max. air flow and the speed are measured in free air ; max. air pressure is measured at zero air flow.  
 \* Noise is measured in anechoic chamber in free air, one meter from intake side.  
 \* All readings are typical values at rated voltage.  
 \* Specifications are subject to change without notice.

北京永宏诚大机电设备有限公司 电话:86-10-66131492  
 传真:86-10-66162242