

## 产品说明 General Data

耐压Dielectric withstand voltage: AC 1500V (50/60Hz) one minute  
 安全保护Protection: Impedance protection or thermal protection  
 工作温度Operating Temperature: Ball bearing: -20°C~+75°C  
 Sleeve bearing: -10°C~+70°C  
 使用寿命Life Expectancy: Ball bearing: over 40000 hr. (At 40°C)  
 Sleeve bearing: over 15000 hr. (At 40°C)  
 安规认证Safety: UL>CUL>TUV>CE>CCC  
 重量Weight: 208g



风量Airflow: 24 ~ 39m<sup>3</sup>/hr 14~23CFM

## 尺寸图 Outline

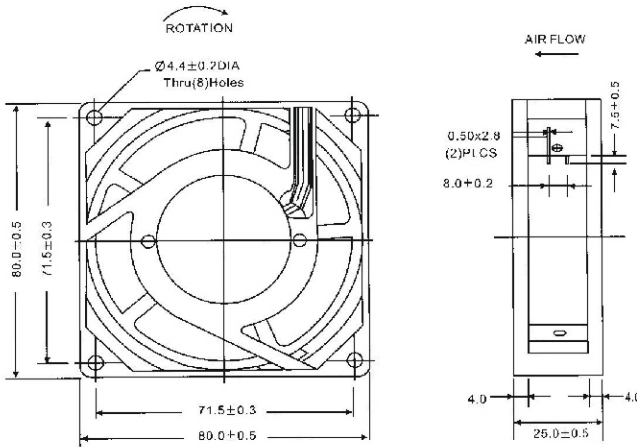

## 材料 Material

外框 Frame: Aluminum alloy  
 风叶 Impeller: Plastic 94V-0 PBT covering glass fiber  
 马达 Motor: Shaded pole induction motor  
 连接方式 Connection: Lead wire

## 开孔尺寸 Panel Cut-outs

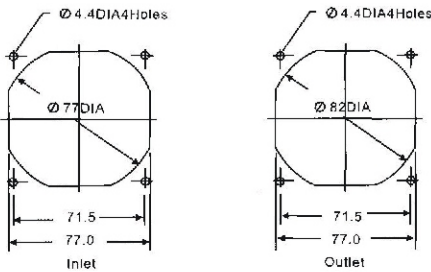

## 曲线图 Characteristic Curves

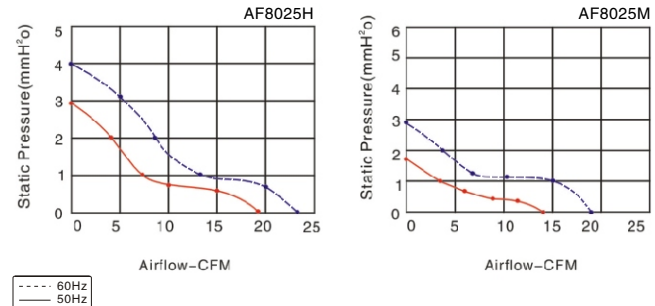

## 技术参数 Specifications

Model (型号)	Bearing system (轴承型式)	Voltage VAC (电压)	Freq. Hz (频率)	Current A (电流)	Power W (功率)	Speed RPM (转速)	Noise dBA (噪音)	Air Flow (风量)		Phase (相数)	Capacitor (电容)
								M3/hr	CFM		
AF8025HA <sub>1</sub> S	Sleeve	100-120	50/60	0.13	13	2300/2700	27/30	32/39	19/23	1	/
AF8025HA <sub>2</sub> S		200-240	50/60	0.7	13	2300/2700	27/30	32/39	19/23	1	/
AF8025HA <sub>1</sub> B	Ball	100-120	50/60	0.13	13	2300/2700	27/30	32/39	19/23	1	/
AF8025HA <sub>2</sub> B		200-240	50/60	0.7	13	2300/2700	27/30	32/39	19/23	1	/
AF8025MA <sub>1</sub> S	Sleeve	100-120	50/60	0.13	13	1700/2200	22/26	24/32	14/19	1	/
AF8025MA <sub>2</sub> S		200-240	50/60	0.7	13	1700/2200	22/26	24/32	14/19	1	/
AF8025MA <sub>1</sub> B	Ball	100-120	50/60	0.13	13	1700/2200	22/26	24/32	14/19	1	/
AF8025MA <sub>2</sub> B		200-240	50/60	0.7	13	1700/2200	22/26	24/32	14/19	1	/